



**NOFFZ**  
TECHNOLOGIES

HDS-HSD/MATEnet/H-MTD 1008

# HIGH-SPEED DATA SWITCH

switch automotive video, automotive ethernet, USB and PCIe



PRODUCT

[noffz.com](http://noffz.com)



**NOFFZ HDS** with different automotive connectors like HSD, MATeNet & H-MTD

### FEAUTRES AND HIGHLIGHTS

- > 8-Port differential high speed data switch
- > Different Automotive connectors like HSD, H-MTD and MATeNet
- > Supports data streams up to 12Gbps
- > Supports bidirectional data stream with backchannel communication
- > Control via Ethernet
- > API for .net, LabVIEW and TestStand are available
- > Easy access with web interface
- > Additional parts like 19" 1HE mounting panel and mounting brackets available

### SUPPORTS

- > Automotive Video  
FPDLink III & IV; GMSL2 & 3; APIX; GVIF; ASA Motion Link
- > Automotive Ethernet  
100BASE-T1; 1000Base-T1;
- > USB 1.0/2.0/3.x
- > PCIe
- > HDBase-T
- > MIPI A-PHY

### EXAMPLE SETUP: DISPLAY TEST WITH HIGHSPEED DATA SWITCH

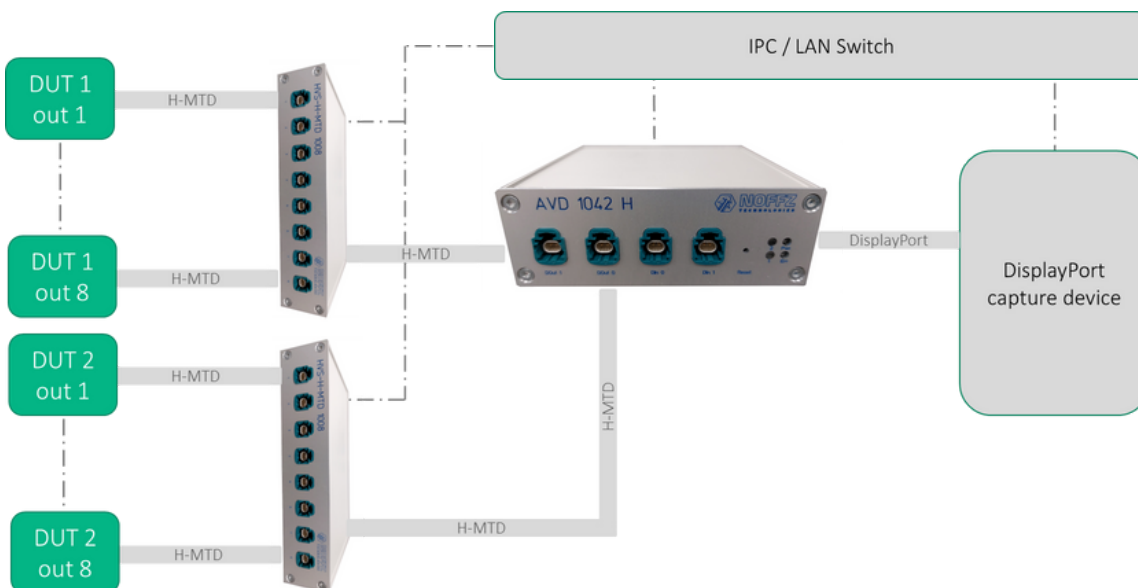



**NOFFZ** Automotive Video Serializer/Deserializer

Front

Rear

### FEAUTRES AND HIGHLIGHTS

- > Supports FPDLinkIII/IV and GMSL 2/3
- > Supports differential and single ended Signals up to 13Gbps (4k)
- > Different connectors like HSD, H-MTD, Fakra and HFM are supported
- > Access to all chip functions and registers over Ethernet
- > Easy access with Webinterface for settings and status information
- > API for .net, Labview and TestStand are available
- > Up to 2 channels in parallel
- > Supports backchanel communication in all directions
- > Small footprint
- > Additional parts like 19" 1HE mounting panel and mounting brackets available

### SERIALIZER (CAMERA)

- > Able to generate different test patterns
- > Displayport video stream can be added
- > Onboard pixel clock generator
- > Loads for DC Test can be connected

### DE-SERIALIZER (DISPLAY)

- > Converts SerDes to Displayport
- > Daisy chain functionality available
- > All chip functions and registers are accessible via Ethernet

### EXAMPLE SETUP: DISPLAY TEST WITH HIGHSPEED DATA SWITCH

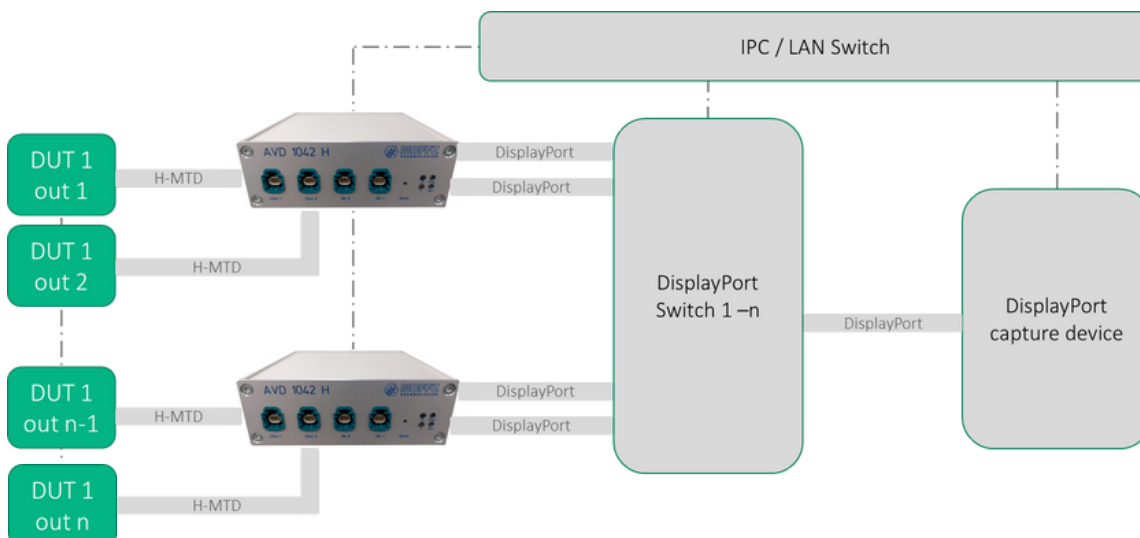

[noffz.com](http://noffz.com)



## EXPERIENCE GLOBAL EXCELLENCE IN TESTING & AUTOMATION

At NOFFZ Technologies, our dynamic innovation and unwavering commitment to customer service have made us a global leader in testing & automation systems. With a worldwide network of locations in USA, Mexico, Germany, Hungary, Serbia, and China, we provide local expertise and prompt support to industries such as automotive, telecommunication, smart homes, medical technology, and semiconductors. Our market-leading technologies, combined with our international team of experts, ensure the successful implementation and operation of our cutting-edge solutions. Experience global excellence in testing & automation with NOFFZ Technologies today.

**NOFFZ** Technologies GmbH

Vorster Strasse 238 · 47918 Toenisvorst · Germany · Phone +49-2151-99878-0 · Fax +49-2151-99878-88 · [info@noffz.com](mailto:info@noffz.com)